

Low Cost Axial Vactrols

VTL5C1, 5C2

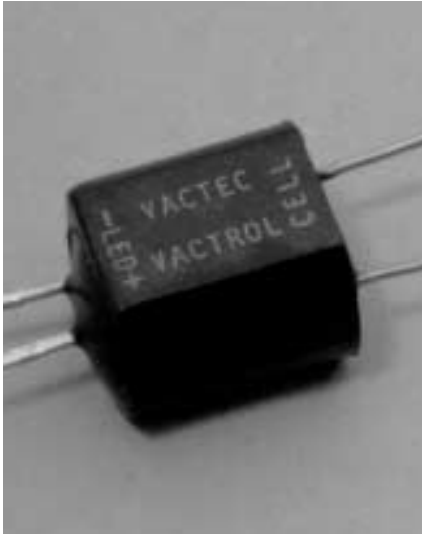

PACKAGE DIMENSIONS inch (mm)

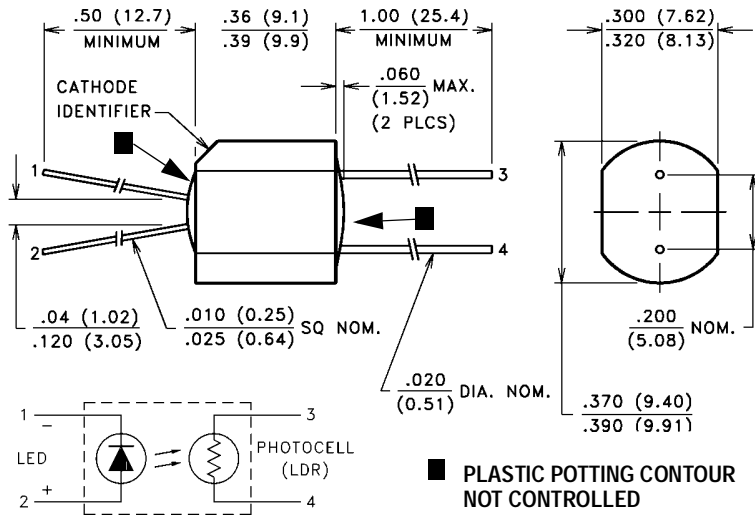

DESCRIPTION

VTL5C1 offers 100db dynamic range, fast response time, and very high dark resistance. VTL5C2 features a very steep slope, low temperature coefficient of resistance, and a small light history memory.

ABSOLUTE MAXIMUM RATINGS @ 25°C

Maximum Temperatures		LED Forward Voltage Drop @ 20 mA:	2.0V (1.65V Typ.)
Storage and Operating:	-40°C to 75°C	Min. Isolation Voltage @ 70% Rel. Humidity:	2500 VRMS
Cell Power:	175 mW	Output Cell Capacitance:	5.0 pF
Derate above 30°C:	3.9 mW/°C	Cell Voltage:	100V (VTL5C1), 200V (VTL5C2)
LED Current:	40 mA 1	Input - Output Coupling Capacitance:	0.5 pF
Derate above 30°C:	0.9 mA/°C		
LED Reverse Breakdown Voltage:	3.0 V		

ELECTRO-OPTICAL CHARACTERISTICS @ 25°C

Part Number	Material Type	ON Resistance 2		OFF 3 Resistance @ 10 sec. (Min.)	Slope (Typ.) @ 0.5 mA / R @ 5 mA	Dynamic Range (Typ.) $\frac{R_{DARK}}{R @ 20 mA}$	Response Time 4	
		Input current	Dark Adapted (Typ.)				Turn-on to 63% Final R_{ON} (Typ.)	Turn-off (Decay) to 100 kΩ (Max.)
VTL5C1	1	1 mA 10 mA 40 mA	20 kΩ 600 Ω 200 Ω	50 MΩ	15	100 db	2.5 ms	35 ms
VTL5C2	0	1 mA 10 mA 40 mA	5.5 kΩ 800 Ω 200 Ω	1 MΩ	24	69 db	3.5 ms	500 ms

Refer to Specification Notes, page 41.

Typical Performance Curves

Output Resistance vs. Input Current
VTL5C1

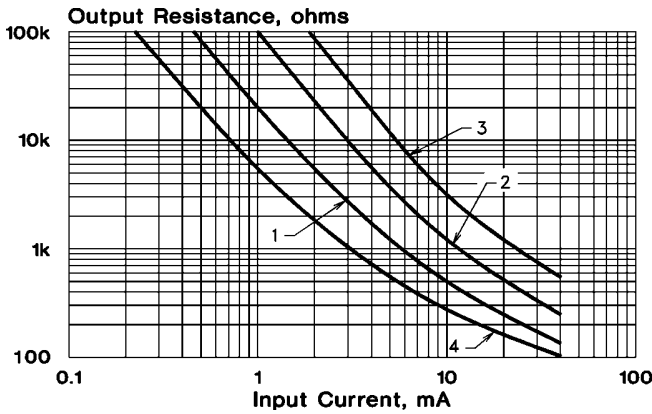

Response Time
VTL5C1

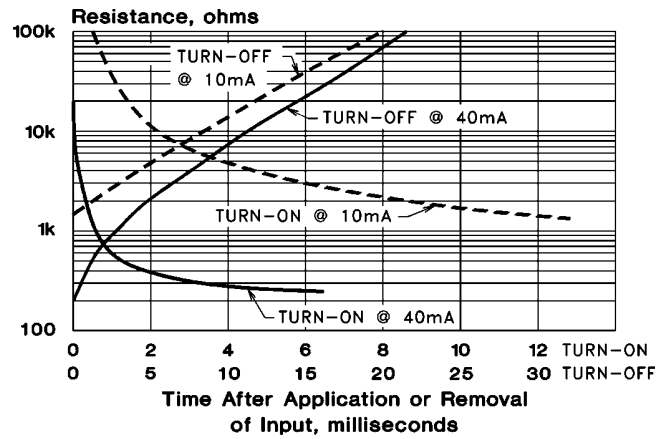

Output Resistance vs. Input Current
VTL5C2

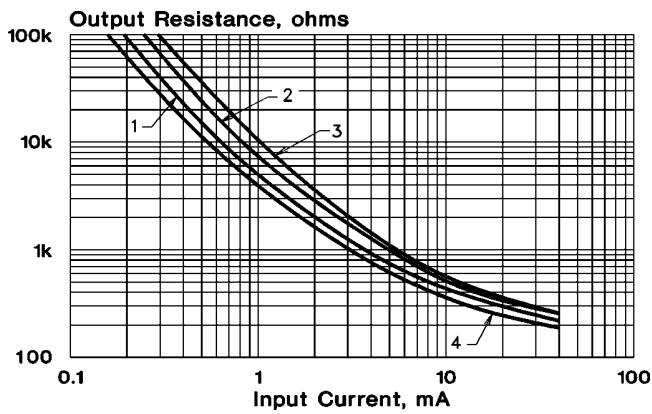

Response Time
VTL5C2

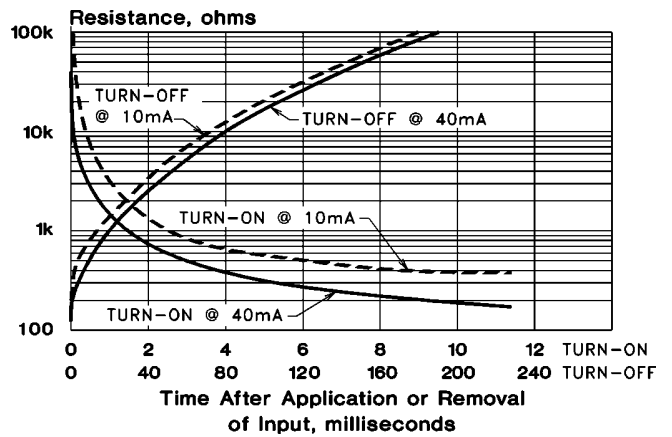

Input Characteristics

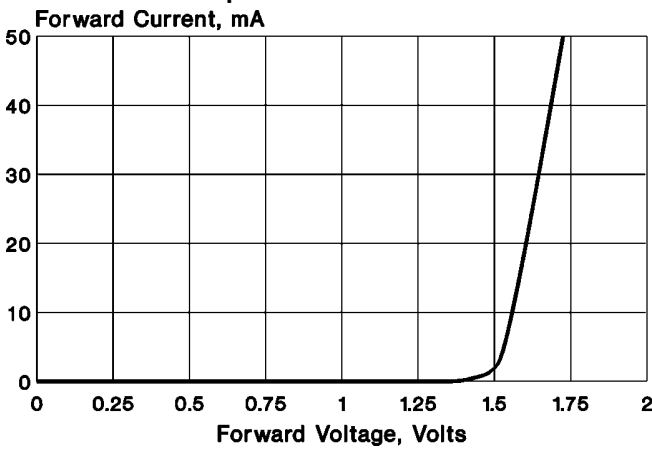

Notes:

- At 1.0 mA and below, units may have substantially higher resistance than shown in the typical curves. Consult factory if closely controlled characteristics are required at low input currents.
- Output resistance vs input current transfer curves are given for the following light adapt conditions:
 - 25°C — 24 hours @ no input
 - 25°C — 24 hours @ 40 mA input
 - +50°C — 24 hours @ 40 mA input
 - 20°C — 24 hours @ 40 mA input
- Response time characteristics are based upon test following adapt condition (2) above.

Dual Element Axial Vactrols

VTL5C2/2, 5C3/2

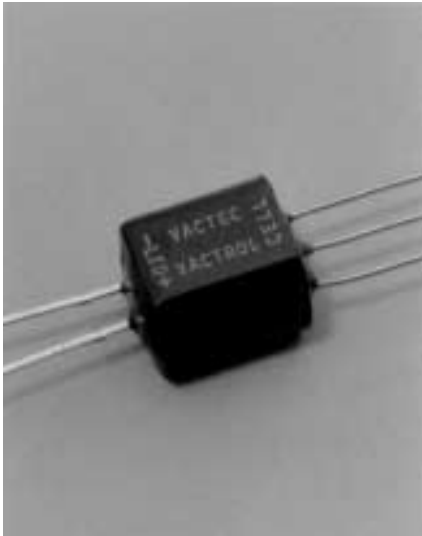

PACKAGE DIMENSIONS INCH (MM)

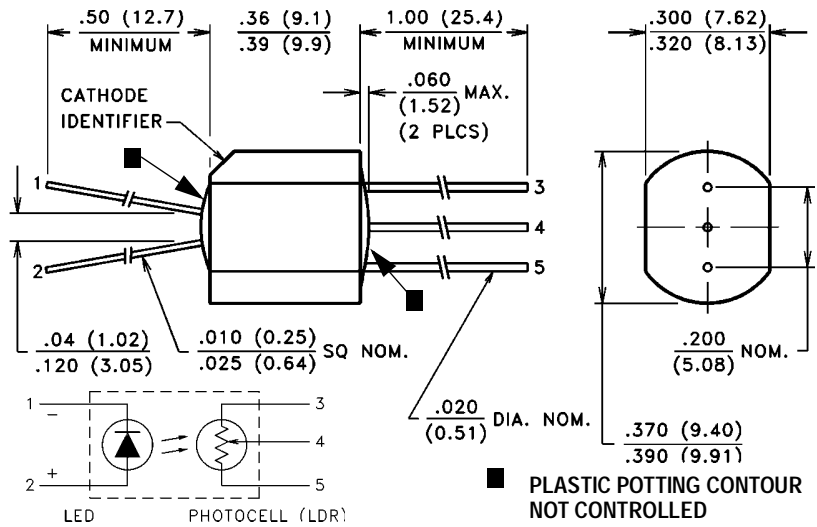

DESCRIPTION

VTL5C2/2 features a very steep slope, low temperature coefficient of resistance, and a small light history memory.

VTL5C3/2 has a steep slope, good dynamic range, a very low temperature coefficient of resistance, and a small light history memory.

ABSOLUTE MAXIMUM RATINGS @ 25°C

Maximum Temperatures

Storage and Operating: -40°C to 75°C

Cell Power: 175 mW

Derate above 30°C: 3.9 mW/°C

LED Current: 40 mA **1**

Derate above 30°C: 0.9 mA/°C

LED Reverse Breakdown Voltage: 3.0 V

LED Forward Voltage Drop @ 20 mA: 2.0V (1.65V Typ.)

Min. Isolation Voltage @ 70% Rel. Humidity: 2500 VRMS

Output Cell Capacitance: 5.0 pF

Cell Voltage: 50V (VTL5C2/2),
100V (VTL5C2/3)

Input - Output Coupling Capacitance: 0.5 pF

ELECTRO-OPTICAL CHARACTERISTICS @ 25°C

Part Number	Material Type	ON Resistance 2		OFF 3 Resistance @ 10 sec. (Min.)	Slope (Typ.) @ 0.5 mA / R @ 5 mA	Dynamic Range (Typ.) $\frac{R_{DARK}}{R @ 20 mA}$	Response Time 4	
		Input current	Dark Adapted (Typ.)				Turn-on to 63% Final R_{ON} (Typ.)	Turn-off (Decay) to 100 kΩ (Max.)
VTL5C2/2	Ø	5 mA 40 mA	2.5 kΩ 700 Ω	1.0 MΩ	20	65 db	7.0 ms	150 ms
VTL5C3/2	3	1 mA 40 mA	55 kΩ 2 kΩ	10 MΩ	19	71 db	3.0 ms	50 ms

Refer to Specification Notes, page 41.

Typical Performance Curves

Output Resistance vs. Input Current
VTL5C2/2

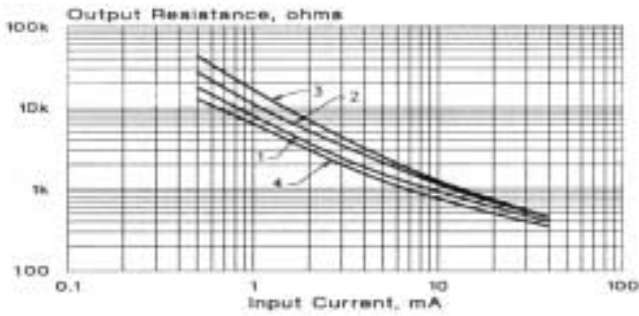

Response Time
VTL5C2/2

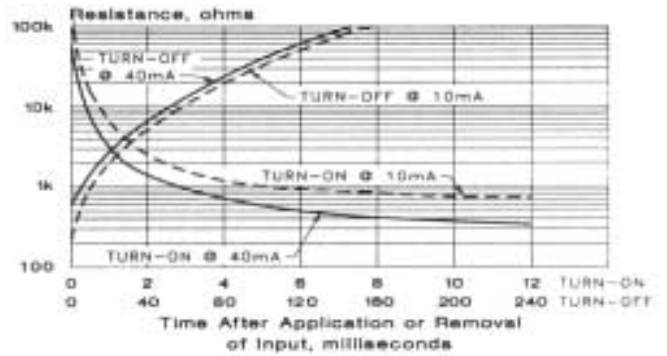

Output Resistance vs. Input Current
VTL5C3/2

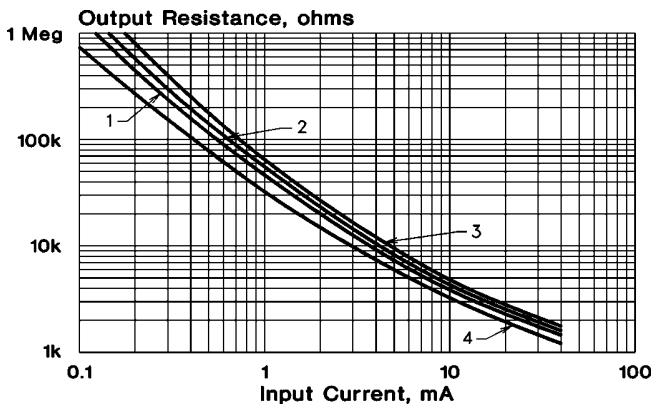

Response Time
VTL5C3/2

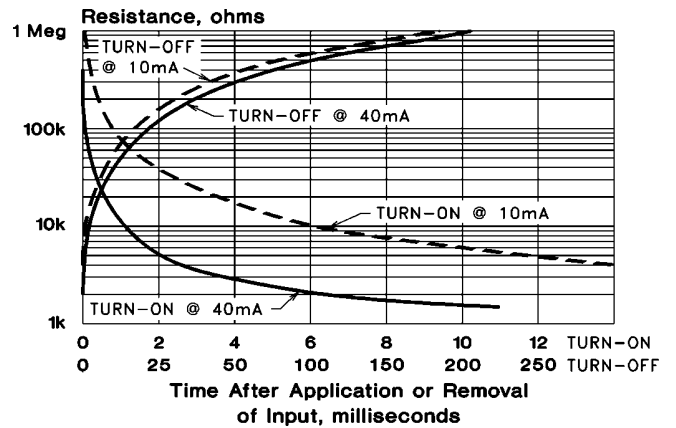

Input Characteristics

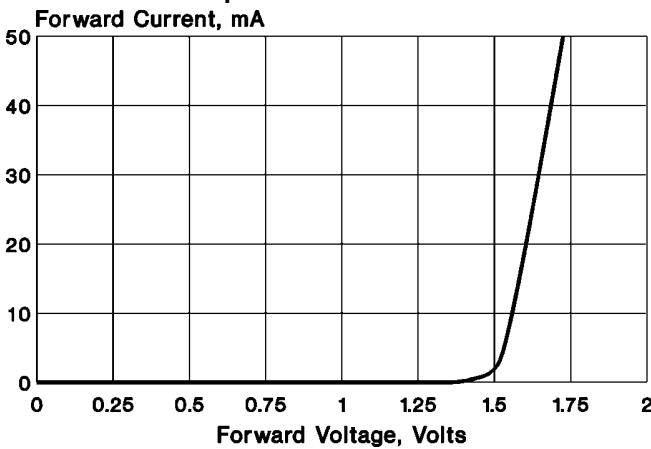

Notes:

- At 1.0 mA and below, units may have substantially higher resistance than shown in the typical curves. Consult factory if closely controlled characteristics are required at low input currents.
- Output resistance vs input current transfer curves are given for the following light adapt conditions:
 - 25°C — 24 hours @ no input
 - 25°C — 24 hours @ 40 mA input
 - +50°C — 24 hours @ 40 mA input
 - 20°C — 24 hours @ 40 mA input
- Response time characteristics are based upon test following adapt condition (2) above.

Low Cost Axial Vactrols

VTL5C3, 5C4

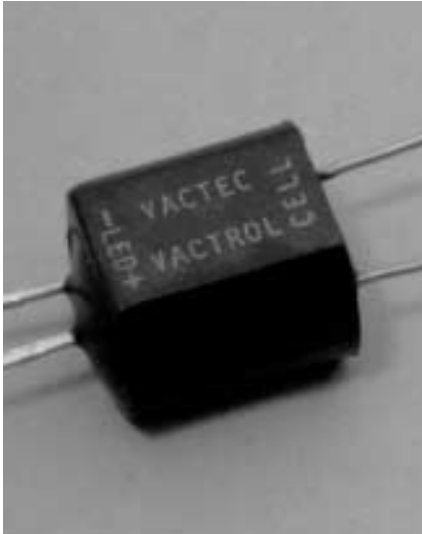

PACKAGE DIMENSIONS INCH (MM)

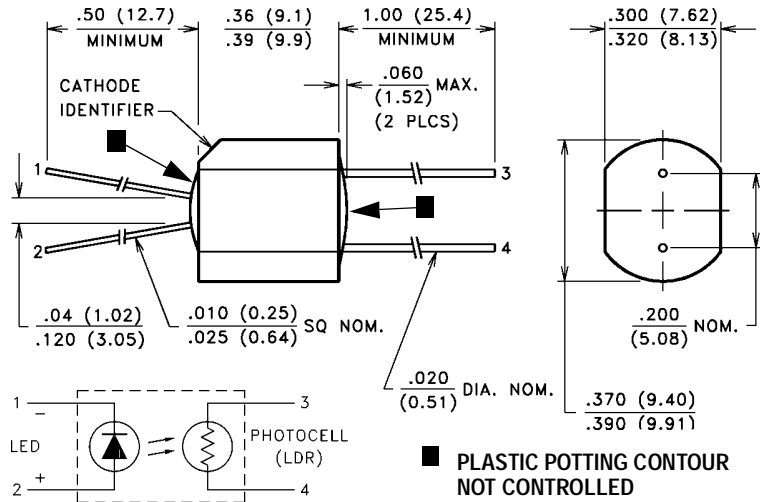

DESCRIPTION

VTL5C3 has a steep slope, good dynamic range, a very low temperature coefficient of resistance, and a small light history memory. VTL5C4 features a very low "on" resistance, fast response time, with a smaller temperature coefficient of resistance than VTL5C1.

ABSOLUTE MAXIMUM RATINGS @ 25°C

Maximum Temperatures		LED Forward Voltage Drop @ 20 mA:	2.0V (1.65V Typ.)
Storage and Operating:	-40°C to 75°C	Min. Isolation Voltage @ 70% Rel. Humidity:	2500 VRMS
Cell Power:	175 mW	Output Cell Capacitance:	5.0 pF
Derate above 30°C:	3.9 mW/°C	Cell Voltage:	250V (VTL5C3), 50V (VTL5C4)
LED Current:	40 mA 1	Input - Output Coupling Capacitance:	0.5 pF
Derate above 30°C:	0.9 mA/°C		
LED Reverse Breakdown Voltage:	3.0 V		

ELECTRO-OPTICAL CHARACTERISTICS @ 25°C

Part Number	Material Type	ON Resistance 2		OFF Resistance 3 @ 10 sec. (Min.)	Slope (Typ.) $\frac{R@ 0.5 \text{ mA}}{R@ 5 \text{ mA}}$	Dynamic Range (Typ.) $\frac{R_{\text{DARK}}}{R@ 20 \text{ mA}}$	Response Time 4	
		Input current	Dark Adapted (Typ.)				Turn-on to 63% Final R_{ON} (Typ.)	Turn-off (Decay) to 100 k Ω (Max.)
VTL5C3	3	1 mA 10 mA 40 mA	30 k Ω 5 Ω 1.5 Ω	10 M Ω	20	75 db	2.5 ms	35 ms
VTL5C4	4	1 mA 10 mA 40 mA	1.2 k Ω 125 Ω 75 Ω	400 M Ω	18.7	72 db	6.0 ms	1.5 sec

Refer to Specification Notes, page 41.

Typical Performance Curves

Output Resistance vs. Input Current
VTL5C3

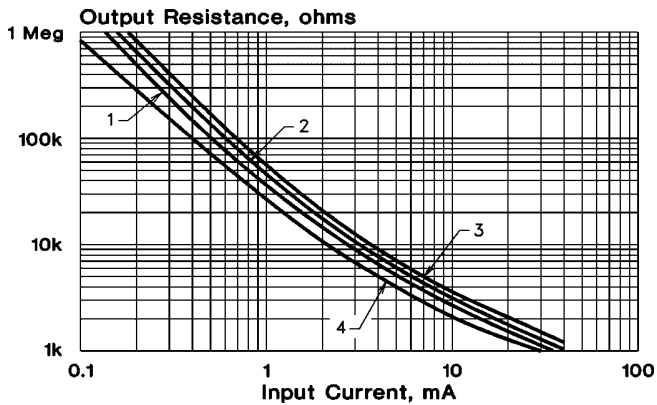

Response Time
VTL5C3

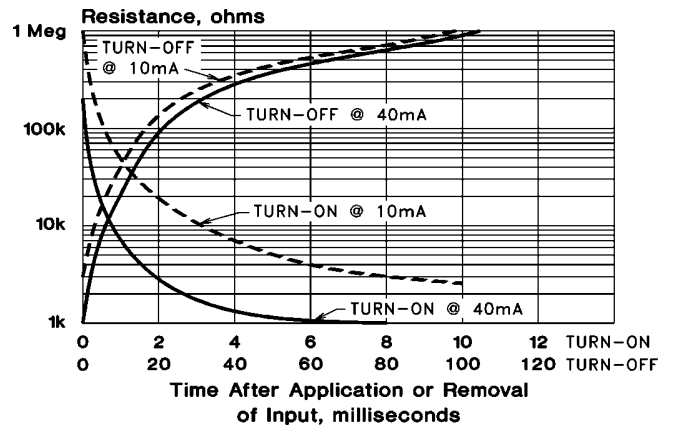

Output Resistance vs. Input Current
VTL5C4

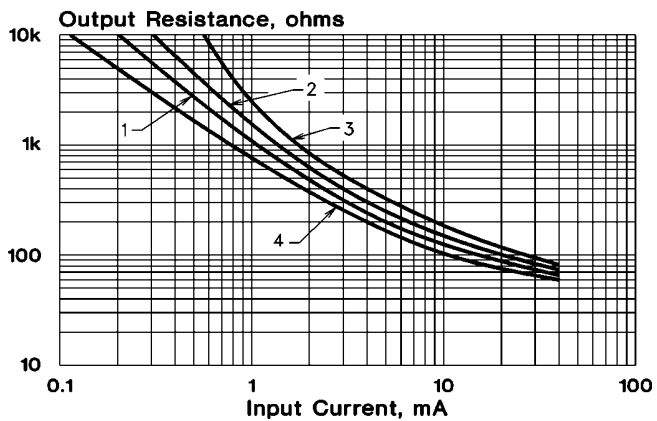

Response Time
VTL5C4

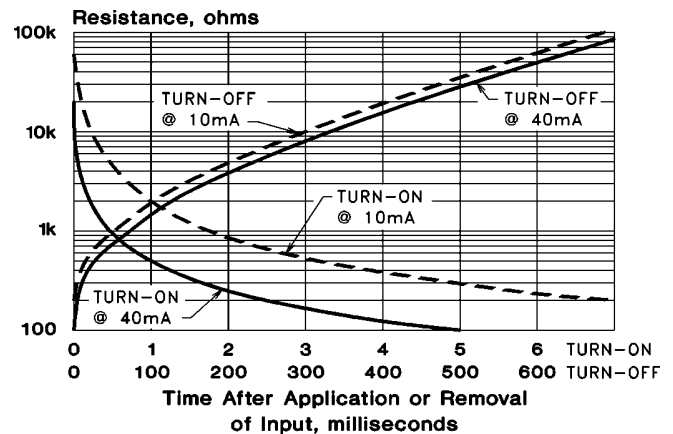

Input Characteristics

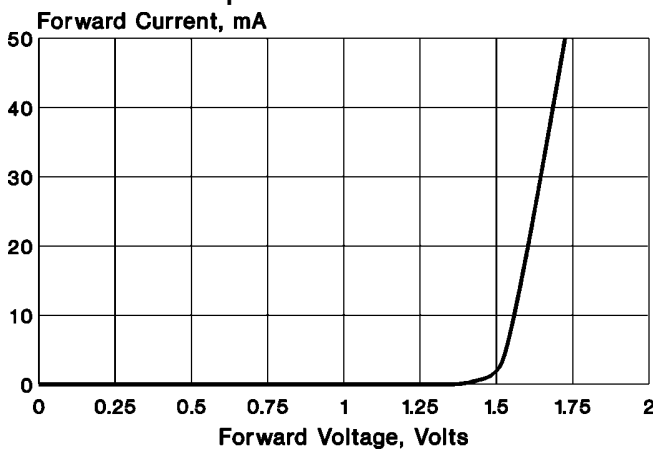

Notes:

- At 1.0 mA and below, units may have substantially higher resistance than shown in the typical curves. Consult factory if closely controlled characteristics are required at low input currents.
- Output resistance vs input current transfer curves are given for the following light adapt conditions:
 - 25°C — 24 hours @ no input
 - 25°C — 24 hours @ 40 mA input
 - +50°C — 24 hours @ 40 mA input
 - 20°C — 24 hours @ 40 mA input
- Response time characteristics are based upon test following adapt condition (2) above.

Dual Element Axial Vactrols

VTL5C4/2

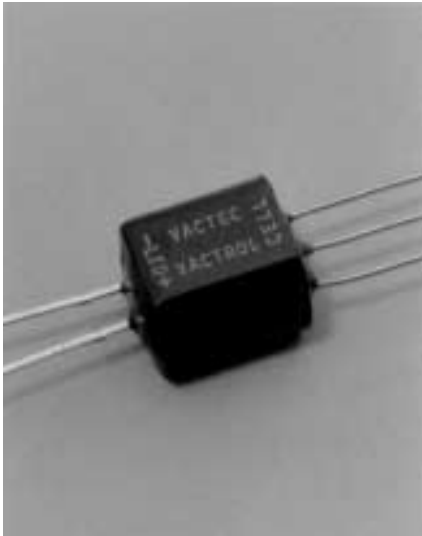

PACKAGE DIMENSIONS INCH (MM)

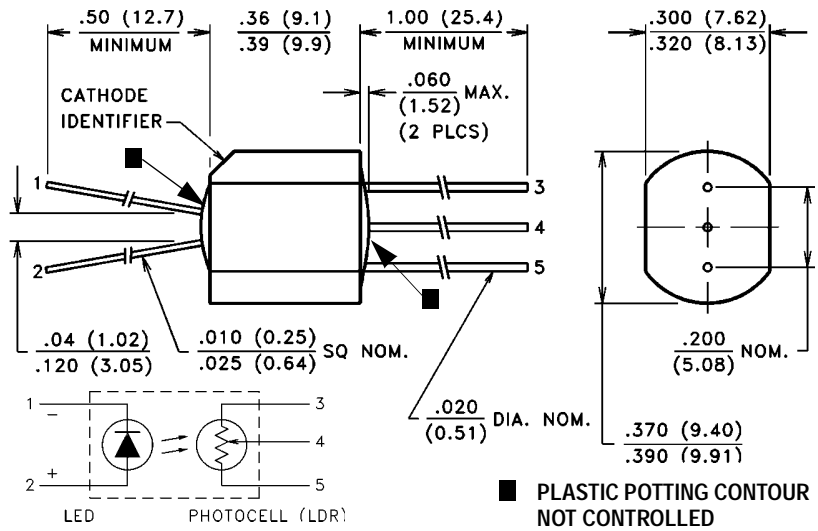

DESCRIPTION

VTL5C4/2 features a very low "on" resistance, fast response time, with a smaller temperature coefficient of resistance than VTL5C1.

ABSOLUTE MAXIMUM RATINGS @ 25°C

Maximum Temperatures		LED Forward Voltage Drop @ 20 mA:	2.0V (1.65V Typ.)
Storage and Operating:	-40°C to 75°C	Min. Isolation Voltage @ 70% Rel. Humidity:	2500 VRMS
Cell Power:	175 mW	Output Cell Capacitance:	5.0 pF
Derate above 30°C:	3.9 mW/°C	Cell Voltage:	30V
LED Current:	40 mA 1	Input - Output Coupling Capacitance:	0.5 pF
Derate above 30°C:	0.9 mA/°C		
LED Reverse Breakdown Voltage:	3.0 V		

ELECTRO-OPTICAL CHARACTERISTICS @ 25°C

Part Number	Material Type	ON Resistance 2		OFF 3 Resistance @ 10 sec. (Min.)	Slope (Typ.) @ 0.5 mA / R @ 5 mA	Dynamic Range (Typ.) $\frac{R_{DARK}}{R @ 20 mA}$	Response Time 4	
		Input current	Dark Adapted (Typ.)				Turn-on to 63% Final R_{ON} (Typ.)	Turn-off (Decay) to 100 kΩ (Max.)
VTL5C4/2	4	1 mA 10 mA	1.5 kΩ 150 Ω	400 Ω	8.3	68 db	6.0 ms	1.5 sec

Refer to Specification Notes, page 41.

Typical Performance Curves (Per Element)

Output Resistance vs. Input Current
VTL5C4/2

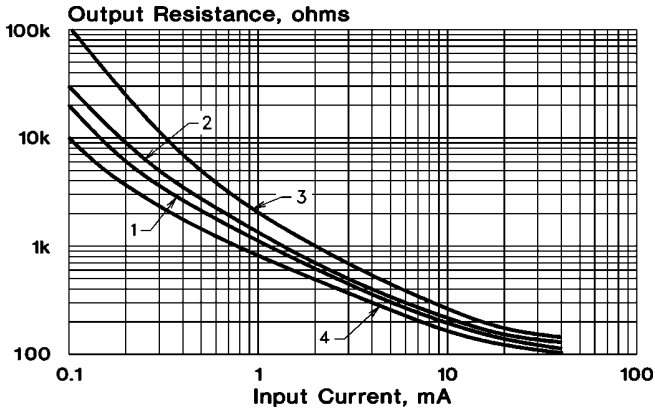

Response Time
VTL5C4/2

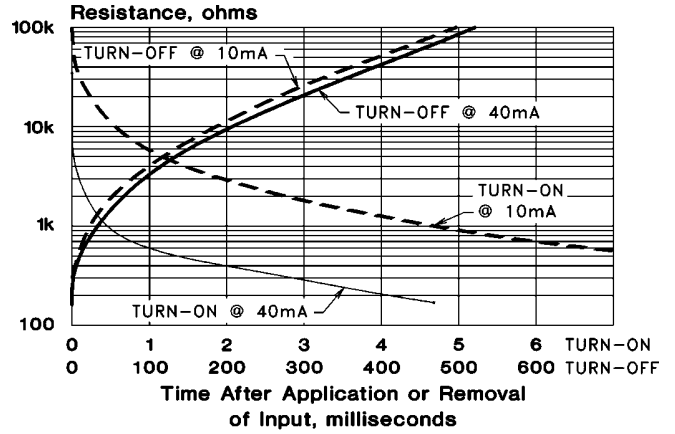

Input Characteristics

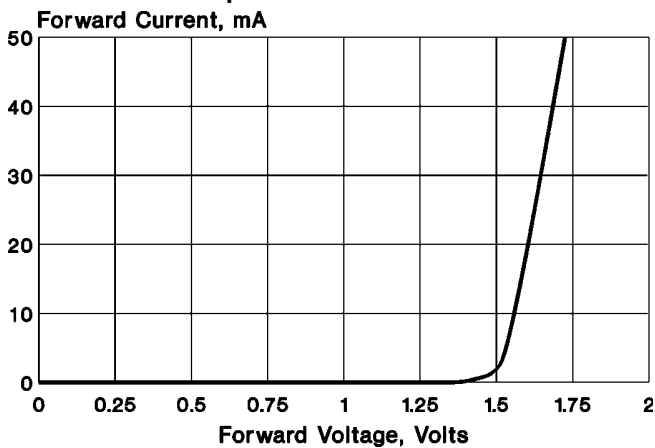

Notes:

1. At 1.0 mA and below, units may have substantially higher resistance than shown in the typical curves. Consult factory if closely controlled characteristics are required at low input currents.
2. Output resistance vs input current transfer curves are given for the following light adapt conditions:
 - (1) 25°C — 24 hours @ no input
 - (2) 25°C — 24 hours @ 40 mA input
 - (3) +50°C — 24 hours @ 40 mA input
 - (4) -20°C — 24 hours @ 40 mA input
3. Response time characteristics are based upon test following adapt condition (2) above.

Low Cost Axial Vactrols

VTL5C6, 5C7

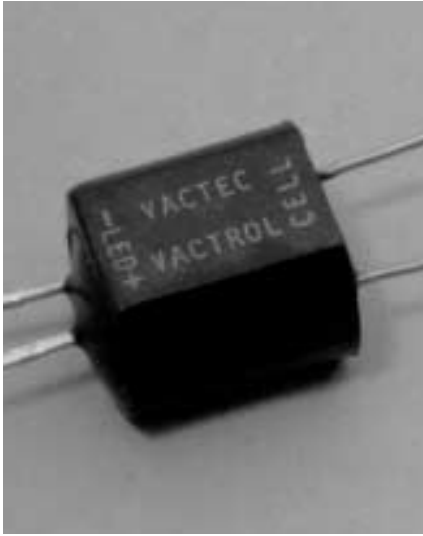

PACKAGE DIMENSIONS INCH (MM)

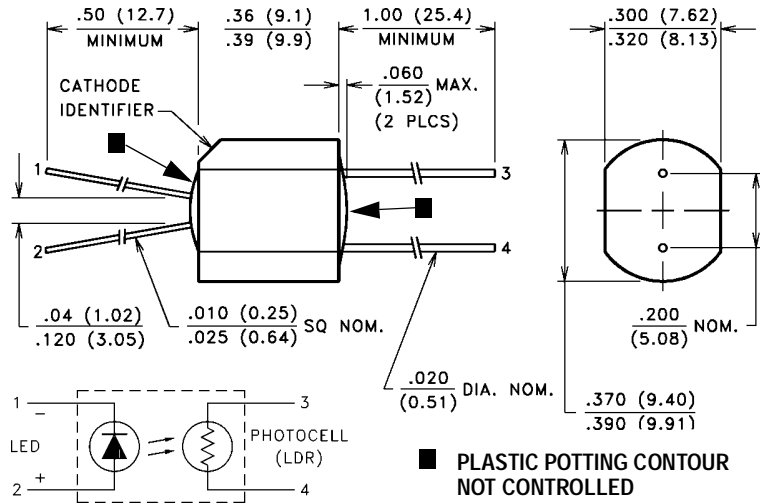

DESCRIPTION

VTL5C6 has a large dynamic range, high dark resistance, a low temperature coefficient of resistance, and a small light history memory. VTL5C7 is a shallow sloped device with good dynamic range, average temperature coefficient of resistance, speed of response, and light history memory.

ABSOLUTE MAXIMUM RATINGS @ 25°C

Maximum Temperatures		LED Forward Voltage Drop @ 20 mA:	2.0V (1.65V Typ.)
Storage and Operating:	-40°C to 75°C	Min. Isolation Voltage @ 70% Rel. Humidity:	2500 VRMS
Cell Power:	175 mW	Output Cell Capacitance:	5.0 pF
Derate above 30°C:	3.9 mW/°C	Cell Voltage:	250V (VTL5C6), 50V (VTL5C7)
LED Current:	40 mA 1	Input - Output Coupling Capacitance:	0.5 pF
Derate above 30°C:	0.9 mA/°C		
LED Reverse Breakdown Voltage:	3.0 V		

ELECTRO-OPTICAL CHARACTERISTICS @ 25°C

Part Number	Material Type	ON Resistance 2		OFF 3 Resistance @ 10 sec. (Min.)	Slope (Typ.) @ 0.5 mA / R @ 5 mA	Dynamic Range (Typ.) R _{DARK} / R @ 20 mA	Response Time 4		
		Input current	Dark Adapted (Typ.)				Turn-on to 63% Final R _{ON} (Typ.)	Turn-off (Decay) to (Max.)	
								1 MΩ	100 kΩ
VTL5C6	0	1 mA 10 mA 40 mA	75 kΩ 10 kΩ 2 kΩ	100 MΩ	16.7	88 db	3.5 ms	50 ms	
VTL5C7	7	0.4 mA 2 mA	5 kΩ 1.1 kΩ	1 MΩ	5.7	75 db	6.0 ms		1 sec

Refer to Specification Notes, page 41.

Typical Performance Curves

Output Resistance vs. Input Current
VTL5C6

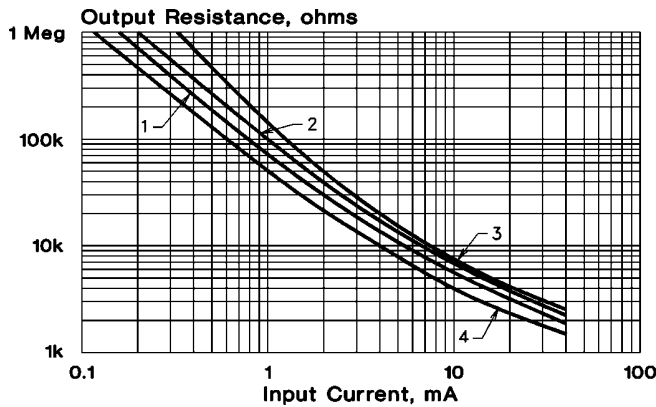

Response Time
VTL5C6

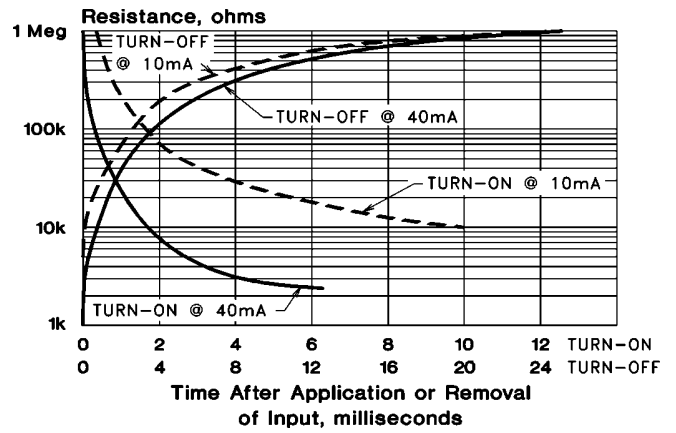

Output Resistance vs. Input Current
VTL5C7

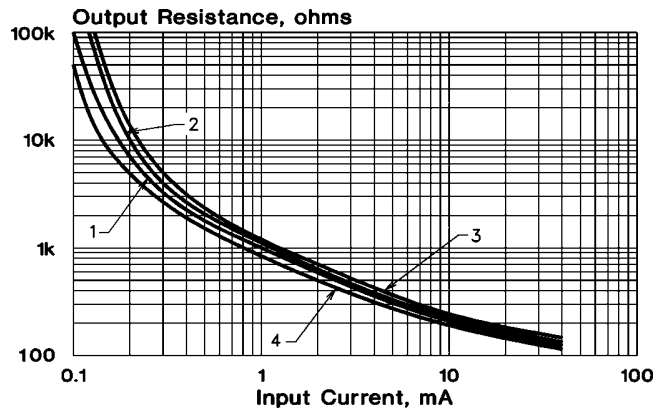

Response Time
VTL5C7

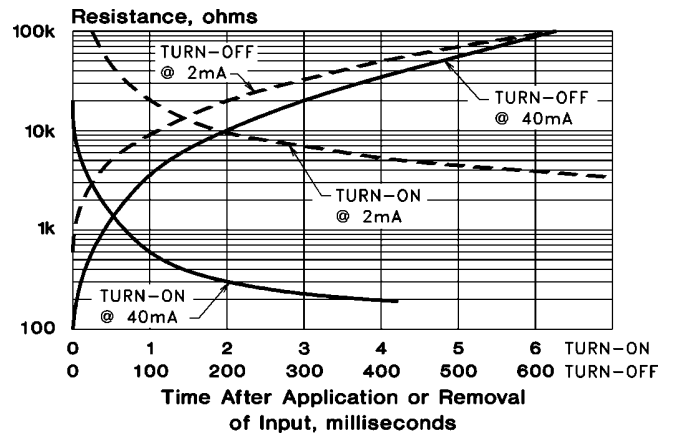

Input Characteristics

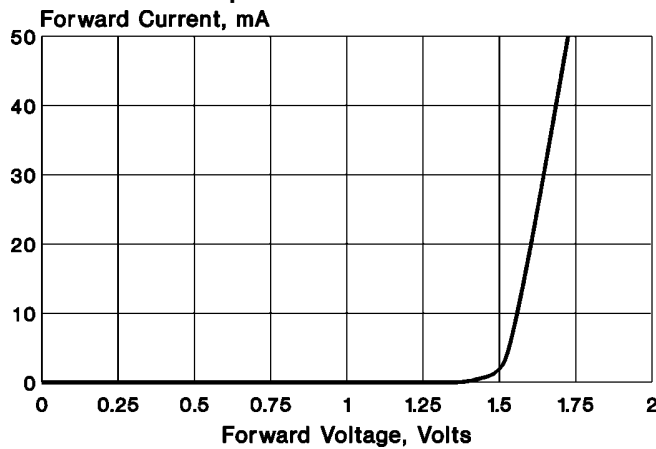

Notes:

1. At 1.0 mA and below, units may have substantially higher resistance than shown in the typical curves. Consult factory if closely controlled characteristics are required at low input currents.
2. Output resistance vs input current transfer curves are given for the following light adapt conditions:
 - (1) 25°C — 24 hours @ no input
 - (2) 25°C — 24 hours @ 40 mA input
 - (3) +50°C — 24 hours @ 40 mA input
 - (4) -20°C — 24 hours @ 40 mA input
3. Response time characteristics are based upon test following adapt condition (2) above.

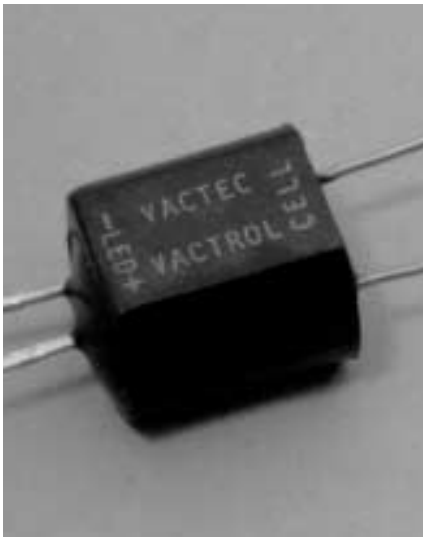

PACKAGE DIMENSIONS INCH (MM)

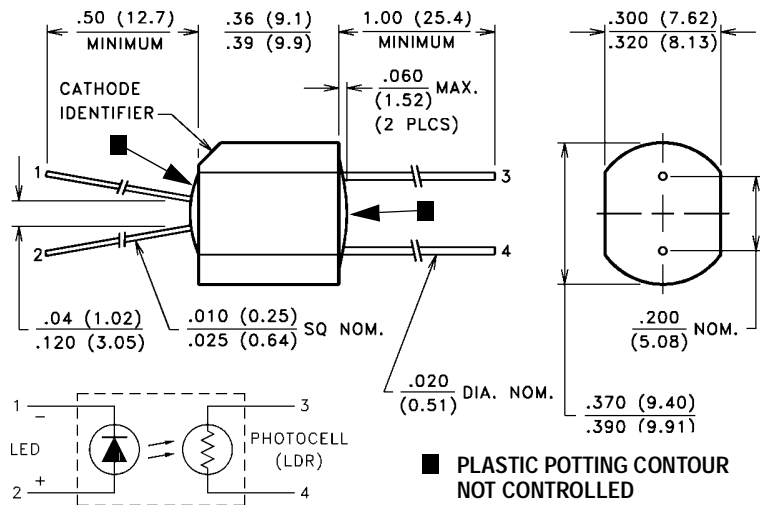

DESCRIPTION

VTL5C8 is similar to VTL5C2 with a low temperature coefficient of resistance and little light history memory, but has a more shallow slope and a lower "on" resistance at low (1 mA) drive currents.

ABSOLUTE MAXIMUM RATINGS @ 25°C

Maximum Temperatures		LED Forward Voltage Drop @ 20 mA:	2.8V (2.2V Typ.)
Storage and Operating:	-40°C to 75°C	Min. Isolation Voltage @ 70% Rel. Humidity:	2500 VRMS
Cell Power:	175 mW	Output Cell Capacitance:	5.0 pF
Derate above 30°C:	3.9 mW/°C	Cell Voltage:	500V
LED Current:	40 mA 1	Input - Output Coupling Capacitance:	0.5 pF
Derate above 30°C:	0.9 mA/°C		
LED Reverse Breakdown Voltage:	3.0 V		

ELECTRO-OPTICAL CHARACTERISTICS @ 25°C

Part Number	Material Type	ON Resistance 2		OFF 3 Resistance @ 10 sec. (Min.)	Slope (Typ.) @ 0.5 mA / R @ 5 mA	Dynamic Range (Typ.) $\frac{R_{DARK}}{R @ 20 mA}$	Response Time 4	
		Input current	Dark Adapted (Typ.)				Turn-on to 63% Final R_{ON} (Typ.)	Turn-off (Decay) to 100 kΩ (Max.)
VTL5C8	0	1 mA 4 mA 16 mA	4.8 kΩ 1.8 kΩ 1.0 kΩ	10 MΩ	8	80 db	4 ms	60 ms

Refer to Specification Notes, page 41.

Typical Performance Curves

Output Resistance vs. Input Current
VTL5C8

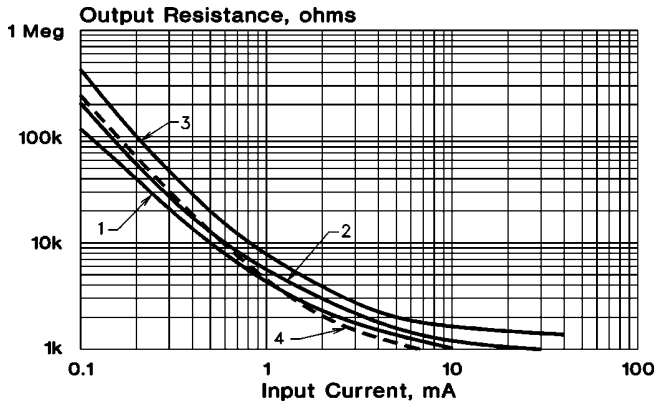

Response Time
VTL5C8

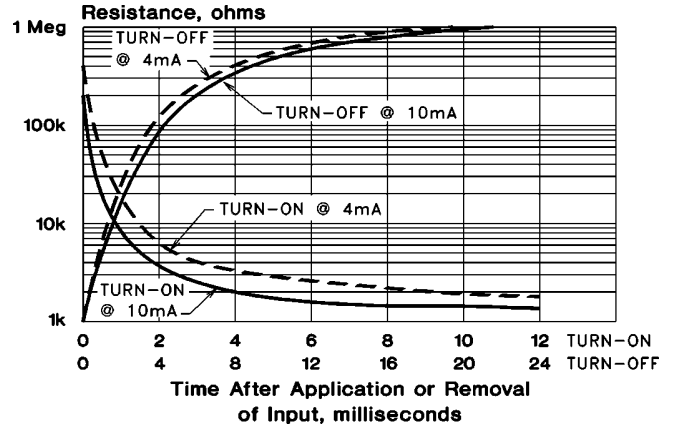

Input Characteristics

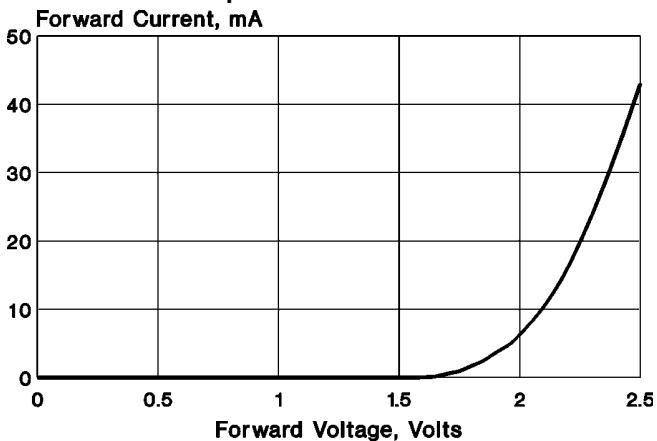

Notes:

- At 1.0 mA and below, units may have substantially higher resistance than shown in the typical curves. Consult factory if closely controlled characteristics are required at low input currents.
- Output resistance vs input current transfer curves are given for the following light adapt conditions:
 - 25°C — 24 hours @ no input
 - 25°C — 24 hours @ 40 mA input
 - +50°C — 24 hours @ 40 mA input
 - 20°C — 24 hours @ 40 mA input
- Response time characteristics are based upon test following adapt condition (2) above.

Low Cost Axial Vactrols

VTL5C9, 5C10

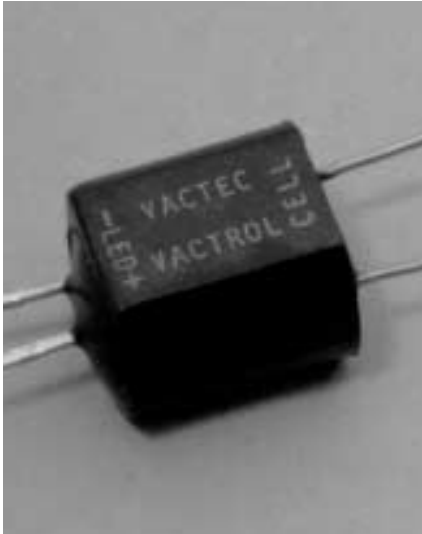

PACKAGE DIMENSIONS INCH (MM)

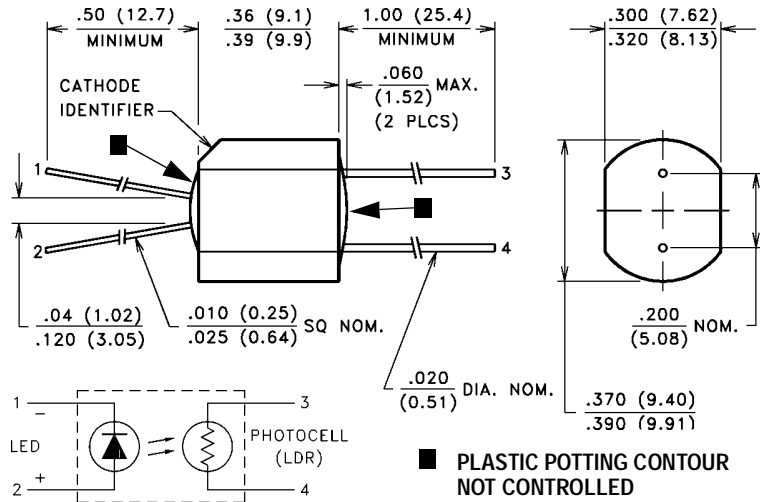

DESCRIPTION

VTL5C9 has a 112 db dynamic range, fast response time, high dark resistance, but with a more shallow slope and lower “on” resistance at low (1 mA) drive currents than the VTL5C1. VTL510 offers a low “on” resistance at low drive currents, a fast response time, and has a smaller temperature coefficient than the VTL5C9.

ABSOLUTE MAXIMUM RATINGS @ 25°C

Maximum Temperatures		LED Forward Voltage Drop @ 20 mA:	2.8V (2.2V Typ.)
Storage and Operating:	-40°C to 75°C	Min. Isolation Voltage @ 70% Rel. Humidity:	2500 VRMS
Cell Power:	175 mW	Output Cell Capacitance:	5.0 pF
Derate above 30°C:	3.9 mW/°C	Cell Voltage:	100V (VTL5C9), 50V (VTL5C10)
LED Current:	40 mA 1	Input - Output Coupling Capacitance:	0.5 pF
Derate above 30°C:	0.9 mA/°C		
LED Reverse Breakdown Voltage:	3.0 V		

ELECTRO-OPTICAL CHARACTERISTICS @ 25°C

Part Number	Material Type	ON Resistance 2		OFF Resistance 3 @ 10 sec. (Min.)	Slope (Typ.) @ 0.5 mA R @ 5 mA	Dynamic Range (Typ.) R _{DARK} R @ 20 mA	Response Time 4	
		Input current	Dark Adapted (Typ.)				Turn-on to 63% Final R _{ON} (Typ.)	Turn-off (Decay) to 100 kΩ (Max.)
VTL5C9	1	2 mA	630 Ω	50 MΩ	7.3	112 db	4.0 ms	50 ms
VTL5C10	4	2 mA	400 Ω	400 KΩ	3.8	75 db	1.0 ms	1.5 sec

Refer to Specification Notes, page 41.

Typical Performance Curves

Output Resistance vs. Input Current
VTL5C9

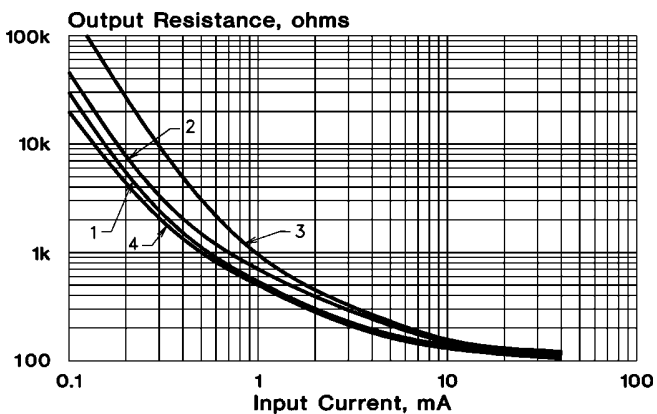

Response Time
VTL5C9

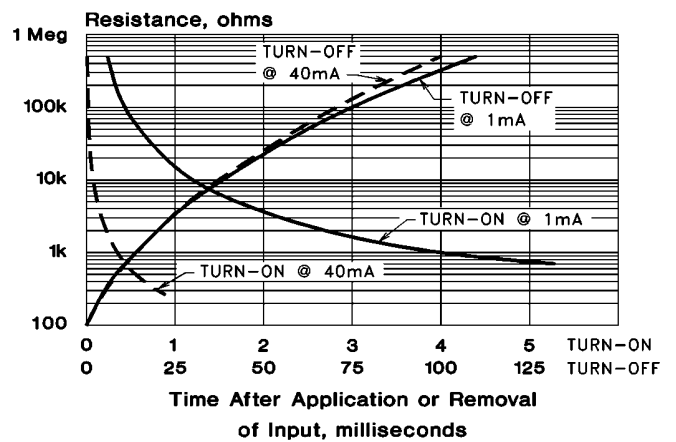

Output Resistance vs. Input Current
VTL5C10

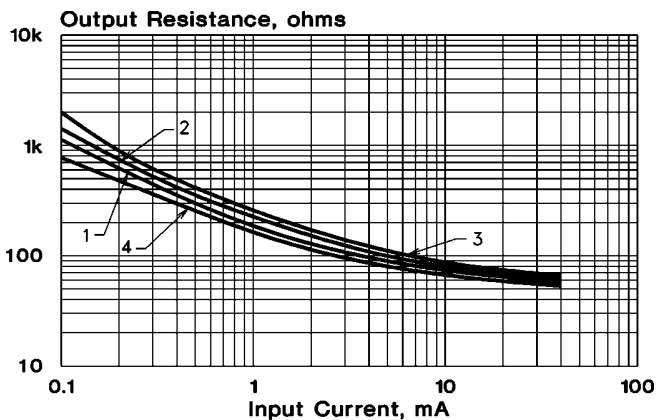

Response Time
VTL5C10

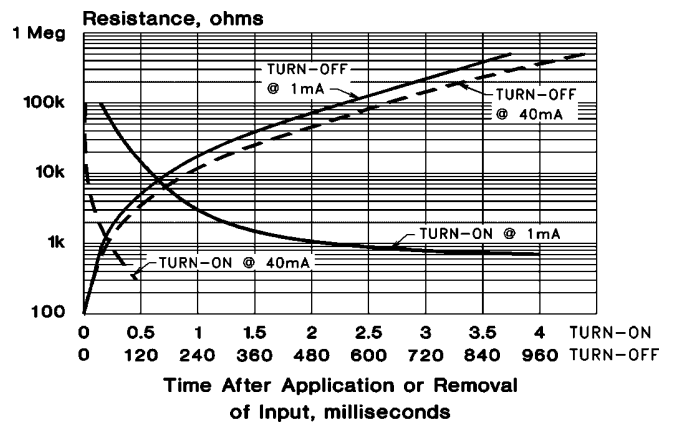

Input Characteristics

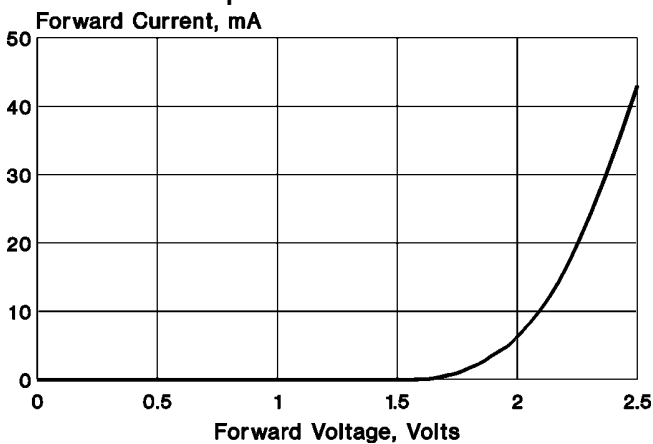

Notes:

- At 1.0 mA and below, units may have substantially higher resistance than shown in the typical curves. Consult factory if closely controlled characteristics are required at low input currents.
- Output resistance vs input current transfer curves are given for the following light adapt conditions:
 - 25°C — 24 hours @ no input
 - 25°C — 24 hours @ 40 mA input
 - +50°C — 24 hours @ 40 mA input
 - 20°C — 24 hours @ 40 mA input
- Response time characteristics are based upon test following adapt condition (2) above.

Application Notes—Analog Optical Isolators

APPLICATION NOTE #1 Audio Applications

The LDR output element of AOIs is almost purely resistive in nature. This property makes the AOI a very useful device for the control of AC signals. Further, because AOIs also possess very low noise and low harmonic distortion characteristics, they are ideal for use as variable resistors, capable of being remotely adjusted in a wide range of audio applications and control circuits.

The focus of this note is on the use of AOIs in audio applications. However, many of the approaches used are equally applicable to higher frequency AC amplification and control circuits.

Control Circuits

Voltage Divider Circuits

The output element of the AOI is a two terminal variable resistor and may be used in a voltage divider circuit as shown in Figures 1a and 1b.

Shunt Input Control

Figure 1a shows the AOI as the shunt element. With $I_F = 0$, the photocell has a very high resistance so $e_{out} = e_{in}$. When I_F is injected into the LED, the AOI output resistance decreases pulling down the output voltage. Since the cell cannot be driven to zero resistance, the value of R_1 must be selected to give the desired maximum attenuation.

A VTL5C4 with a maximum “on” resistance of 200 ohms at $I_F = 10$ mA requires an R_1 of 6100 ohms for 30 db voltage attenuation (producing a 1000:1 power ratio). The actual attenuation ratio will be greater since the 10 mA “on” resistance is typically 125 ohms.

When the maximum I_F is less than 10 mA, the series resistance must be greater to get the same attenuation ratio. If R_1 is made large, the insertion loss (db attenuation at $I_F = 0$) will be higher when the output is loaded. The maximum voltage across the photocell in this circuit is equal to the input voltage assuming no insertion loss. An input voltage as high as 5 – 10V will produce noticeable distortion but that will drop as I_F is increased. To minimize distortion, the voltage across the cell should be kept below 1.0V at the normal operating point.

Series Input Control

With an AOI as the series element as shown in Figure 1b, $e_{out} = 0$ at $I_F = 0$. The maximum voltage across the cell is e_{in} , but decreases as I_F increases.

Op-Amp Feedback Resistor Control

The AOI may also be used as the input or feedback resistor of an operational amplifier. When used in the feedback loop, Figure 1c, a fixed resistor should be used in parallel. With no parallel limiting

resistor, the feedback may approach an open circuit condition at maximum gain. In this open loop state, the circuit becomes unstable and may latch up. The parallel resistor R_3 sets the maximum gain of the amplifier and stabilizes the DC output voltage. Resistor R_2 is in series with the AOI output and sets the minimum gain of the circuit. For op-amps with unity gain compensation, R_2 is set equal to R_3 so the circuit gain does not drop below one. The maximum voltage on the cell (LDR) is e_{out} . If minimizing distortion is a consideration, e_{out} should be kept below 1.0V.

Op-Amp Input Resistor Control

When the AOI is used as the input resistor of an op-amp, Figure 1d, a fixed resistor in series will limit the maximum gain as well as prevent overload of the previous stage.

Non-Inverting Op-Amp Circuits

The AOI can also be used in non-inverting op-amp circuits. Gain is controlled potentiometrically and, again, resistors should be used to limit the maximum gain. The circuit of Figure 1e requires a resistor in series with the AOI, while the circuit of Figure 1f requires one in parallel.

General Considerations

The circuit application and AOI characteristics will influence the choice of circuit to use. In Figure 1a to 1f, gain vs. I_F curves are given for each circuit, as well as input impedance and gain formulas. Once the proper circuit function is selected, AOI response speed must be considered. Because an LDR (photocell) turns “on” fast and “off” slowly, circuits of Figure 1d and 1e will increase in gain rapidly but be slower in the decreasing gain. The circuits of Figure 1c and 1f respond faster when the gain is reduced. All other design considerations are the same as they would be for any op-amp circuit. In all the amplifier configurations, a gain ratio of 1000:1 or higher can be achieved.

Application Notes—Analog Optical Isolators

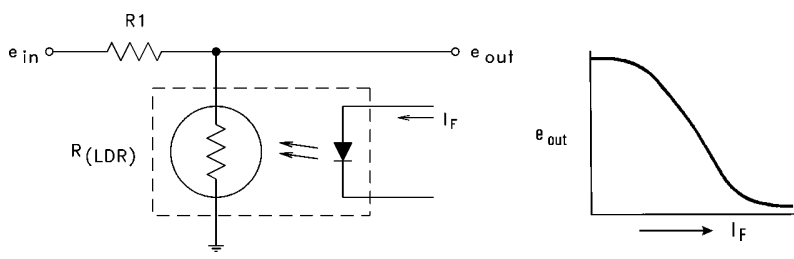
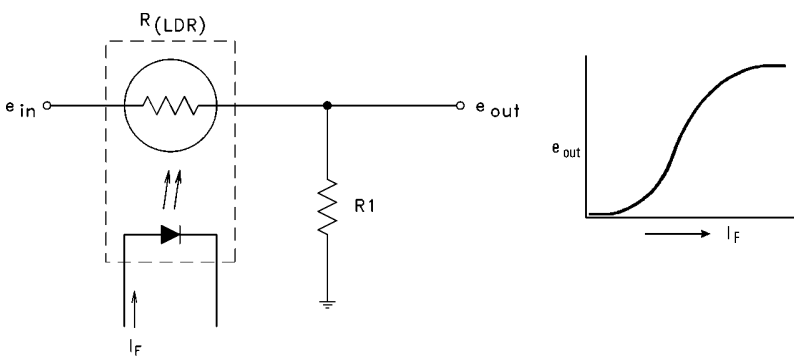
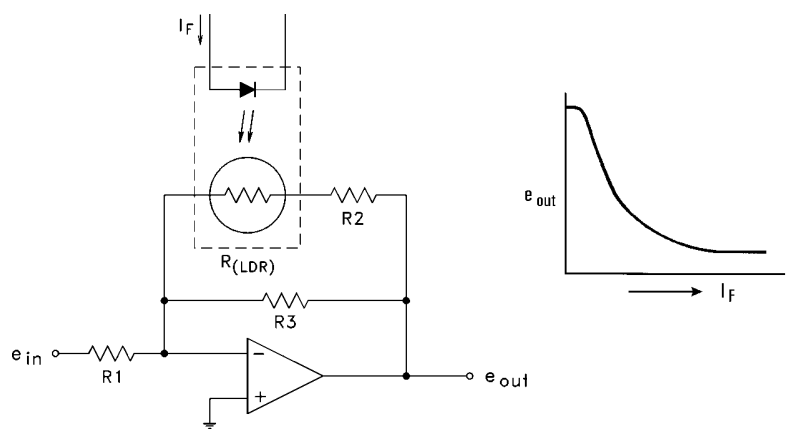
Basic Circuit Configuration	Input Resistance	Gain $\frac{e_{out}}{e_{in}}$
 <p>Figure 1a. Shunt Input Control</p>	Variable	$\frac{R_{(LDR)}}{R_1 + R_{(LDR)}}$
 <p>Figure 1b. Series Input Control</p>	Variable	$\frac{R_1}{R_1 + R_{(LDR)}}$
 <p>Figure 1c. Feedback Resistor Control</p>	Fixed, Low	$\frac{R_3[R_{LDR} + R_2]}{R_1[R_{LDR} + R_2 + R_3]}$

Application Notes—Analog Optical Isolators

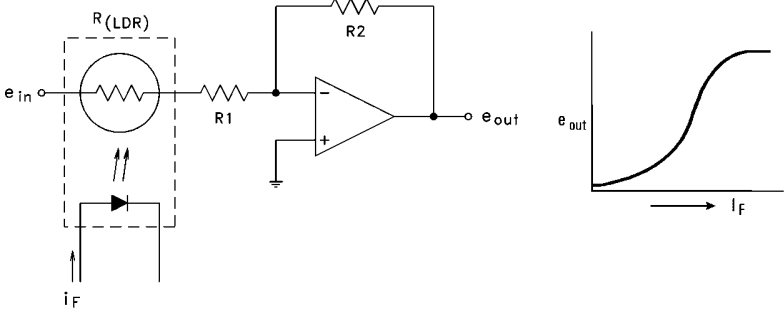
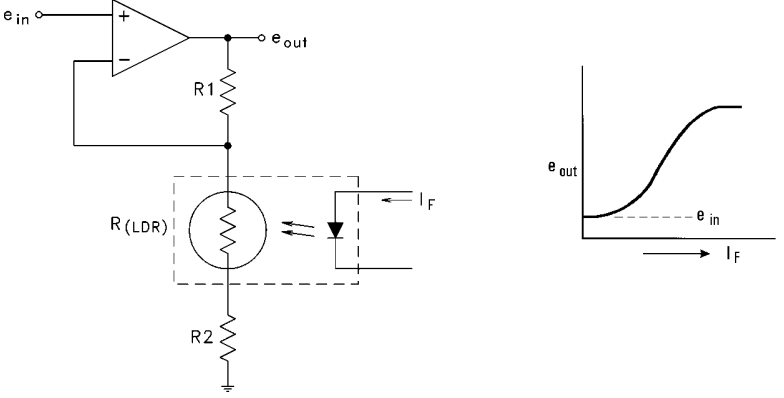
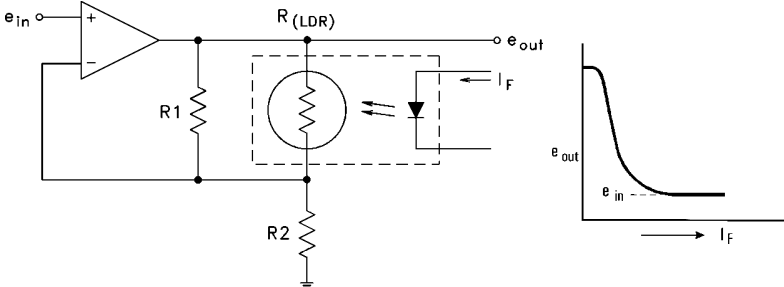
Basic Circuit Configuration	Input Resistance	Gain
 <p data-bbox="375 719 679 748">Figure 1d. Input Resistor Control</p>	Variable	$\frac{R_2}{R_{(LDR)} + R_1}$
 <p data-bbox="384 1211 670 1240">Figure 1e. Potentiometric Gain</p>	Fixed, High	$1 + \frac{R_1}{R_{(LDR)} + R_2}$
 <p data-bbox="384 1597 670 1626">Figure 1f. Potentiometric Gain</p>	Fixed, High	$1 + \frac{R_1 R_{(LDR)}}{R_2 [R_{(LDR)} + R_1]}$

Application Notes—Analog Optical Isolators

Switching

Mechanical switching of low level audio signals requires the use of switches with precious metal contacts. Sudden changes in signal can cause the speakers to thump and damage may occur if the speaker is underdamped. A simple way to avoid these problems is to use an AOI in place of a mechanical switch. In the circuit of Figure 1d, the initial resistance of the LDR cell is so high that amplifier gain is essentially zero. A step change in forward current through the LED is translated into a slower time change in the cell resistance. The resistance drops to 10 times the final value in one millisecond or less. As the resistance continues to drop, the final value is approached exponentially. Express in terms of conductivity:

$$G = G_0[1 - \exp(-t/t_c)] \text{ mhos}$$

and: $R = 1/G \text{ ohms}$

where:

G = conductance, mhos

t = time, ms

t_c = time constant of the photocell, ms

If R_1 is made equal to nine times the final value of resistance, the response to 50% signal will occur in 1.0 ms. The time to get to within

0.5 db of full signal is one time constant, which is usually only a few milliseconds. The step change of a switch has been transformed into a rapid but smooth increase in signal level. In addition, the possibility of turn-on in the middle of a peak has been eliminated.

Turn-off is slower and depends on the ratio of R_1 to the final value of photocell resistance. A high ratio will slow down the turn-off and speed up the turn-on.

This circuit can be extended into a matrix as shown in Figure 2. While a 3 x 3 matrix is shown, the number of nodes is not limited. Individual inputs can be summed into a single output or connected to more than one output. A matrix can be made very compact with the output amplifiers mounted very close to reduce pickup. The op-amps eliminate any crosstalk between the inputs since the summing point is at virtual ground.

The controls for the matrix are usually remotely located. The DC current through the LEDs may be controlled by switches, manual potentiometers, or a computer. The matrix may be used for simple ON-OFF gating, summing of several signals, or proportional control. When proportional control is used, the output should be continuously supervised to correct for changes in signal level due to photocell resistance variation from temperature, light adapt history, and self heating.

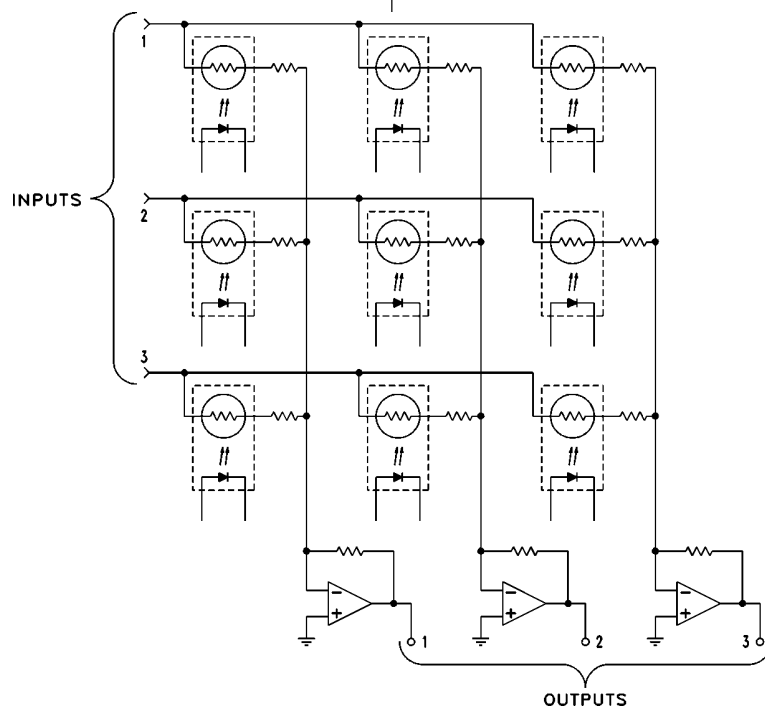

Figure 2. Switching Matrix

Application Notes—Analog Optical Isolators

Gating and Muting

Background noise becomes very objectionable when a signal level in a program is low. Noise is any unwanted sound and may be due to tape hiss or amplifier hum. These noises can be eliminated by selective use of gating and muting, that is, turning the amplifier on when the signal level is high and off when it is low. This technique can also remove or reduce unwanted echo, print through, presence or any other distracting signal during portions of a program which are normally silent. The gating circuit must be completely transparent to the listener, having a smooth, rapid operation with no signal distortion.

A practical gating circuit having these features is shown in Figure 3. The circuit has five basic sections: the threshold adjustment, a high AC gain stage, full-wave rectifier, LED driver and an electrically controlled voltage divider. When the signal is below the threshold level, the voltage divider consisting of the AOI and R₁₀ has maximum attenuation. When the signal exceeds the threshold, the voltage divider allows the signal to pass through.

The circuit operation is as follows. The THRESHOLD potentiometer applies a portion of the signal to the high gain AC amplifier consisting of op-amp A₁, resistors R₂ and R₃ and capacitor C₁. The amplified signal is full-wave rectified by diodes D₁ and D₂ together with op-amp

A₂ which inverts the negative half of the signal. The rectifier charges C₂ used for RELEASE TIME control and drives the base of transistor Q₁, the LED driver. The threshold voltage is a sum of the forward drop of the rectifying diodes, the voltage drop across R₆, V_{BE} or Q₁ and V_F of the LED. This voltage is 2.5 – 3.0V and when referred to the input gives a threshold of 2.5 – 3.0 mV at the amplifier.

The circuit can be set up for a specified threshold voltage. Release time is usually determined empirically. A typical set up procedure uses an audio signal containing spoken dialog. Initially, the THRESHOLD adjustment is set to the maximum and the RELEASE is set to the minimum. The program is turned on and the THRESHOLD is decreased until the audio starts coming through, but sounds chopped up. The chopping occurs because the circuit is too fast on release. The RELEASE is increased until the audio is smoothed out and sounds normal. Setting of the two controls needs to be made carefully. A threshold set too high cuts off the quieter sounds, while a setting which is too low allows more of the noise to come through. Short release time causes more chopping of the audio and can create some distortion at the lower frequencies. Long release time keeps the gate open too long allowing noise to come through after the signal is gone. Adjustments should be made incrementally and worked between the two controls until the best sound is achieved.

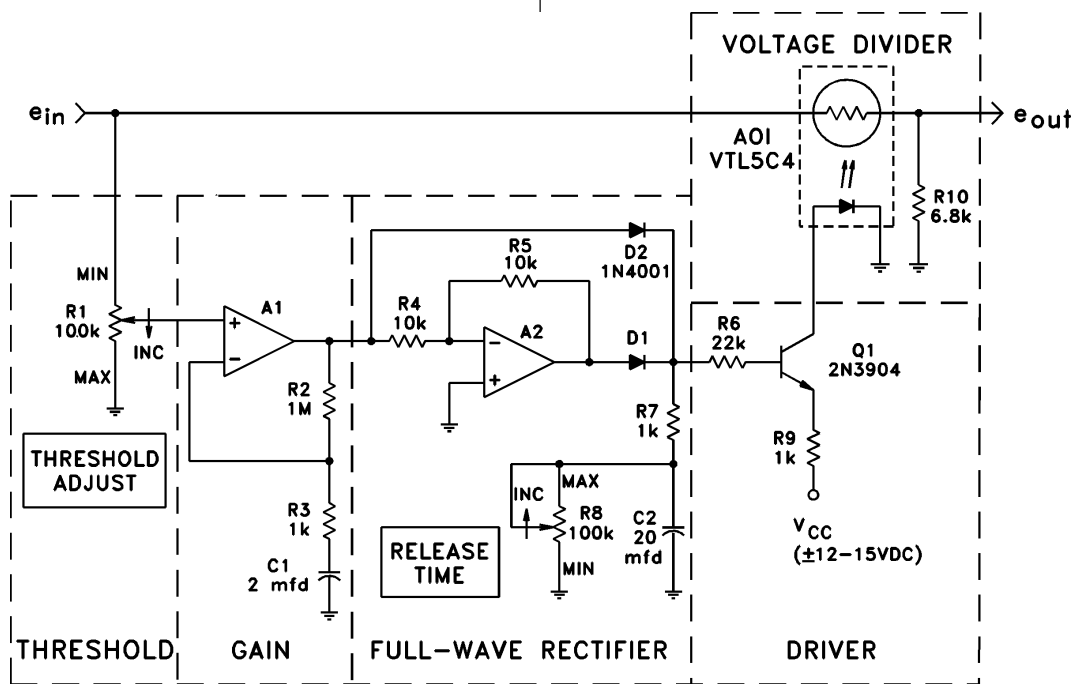

Figure 3. Audio Sound Gate

Application Notes—Analog Optical Isolators

Limiters

If the magnitude of an AC signal varies over a wide range, it may be necessary to amplify or compress the signal before any audio processing can be performed. In other cases, the audio power has to be limited to prevent damage to an output device. Circuits that perform this function on a continual basis need a non-linear element to produce variable gain. However, most non-linear elements introduce distortion. This is unacceptable in a high fidelity audio circuit and other critical applications. Using an AOI, simple circuits can be made to perform this function without introducing distortion or generating any noise.

Signal Limiters

Any circuit that performs as a limiter or compressor must have low gain when the signal magnitude is high and high gain when the signal is low. The gain is adjusted so that a wide dynamic range is compressed into a small one. In other signal processing applications, the signal may need to be virtually constant.

The circuit such as shown in Figure 4a will keep the output level constant when the input voltage varies over a range of 50 – 60 db.

Amplifier A1 operates as an inverting amplifier with a gain:

$$e_{out} / e_{in} = R_{PHOTOCELL} / R_1$$

The feedback resistor is a photocell and has an "off" resistance of 10 megohms, minimum, and an "on" resistance of 5000 ohms with 5.0 mA in the LED. Using the components shown, the gain of this stage varies between 500 with no signal and 0.5 with maximum signal applied. R₂ limits the maximum gain and is needed to prevent the amplifier, A₁

from going open loop when there is no input signal, in which case the cell "off" resistance is much higher than 10 MΩ.

Amplifier A₂ operates as a high input impedance rectifier that drives the LED. The forward drop of the LED is 1.6 – 2.0V, and when the peak output of the rectifier exceeds this value, current will flow into the LED. As the signal increases, more current flows into the LED, driving the photocell resistance lower thus decreasing the amplifier gain. The output of A₁ is regulated at a voltage determined by the forward drop of the LED and the closed loop gain of amplifier A₂. A₂ amplifies the signal by a factor of two, and a 1.8V peak (1.27 VRMS) is required to activate this AOI. This results in the output voltage being held to 0.64 VRMS over a input range of 1 – 600 mV. Changing the value of R₄ changes the gain of the rectifier. Omitting R₄ will double the output voltage because the rectifier gain drops to one. Putting a resistor in series with the LED will cause the regulated voltage to rise as the input is increased (see Figure 4b). As the amplifier gain changes, the amplifier bandwidth also changes. When the signal is low, the amplifier will have the highest gain and lowest bandwidth.

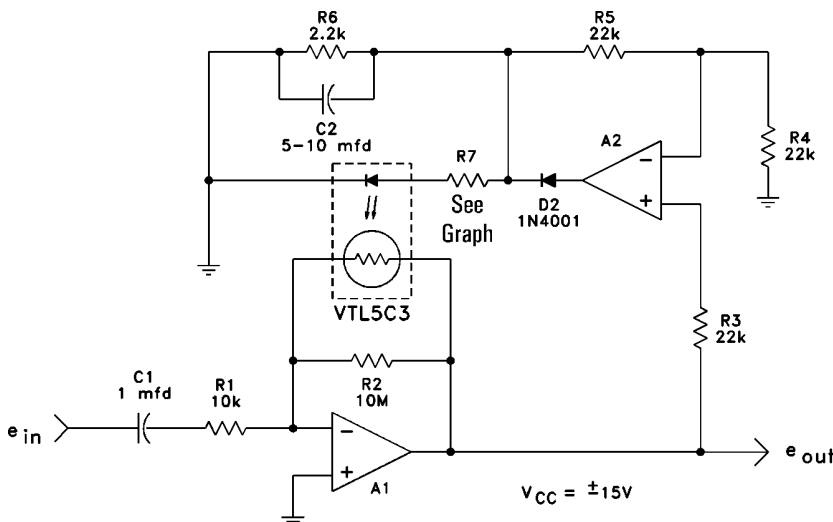

Figure 4a. Peak Sensing Compressor

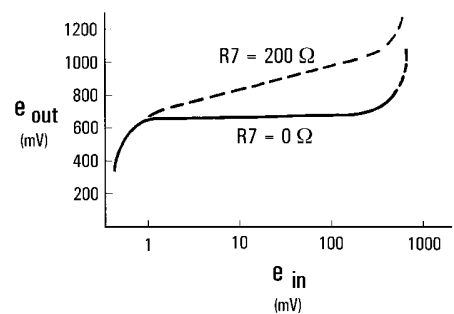

Figure 4b. Output Characteristics

Application Notes—Analog Optical Isolators

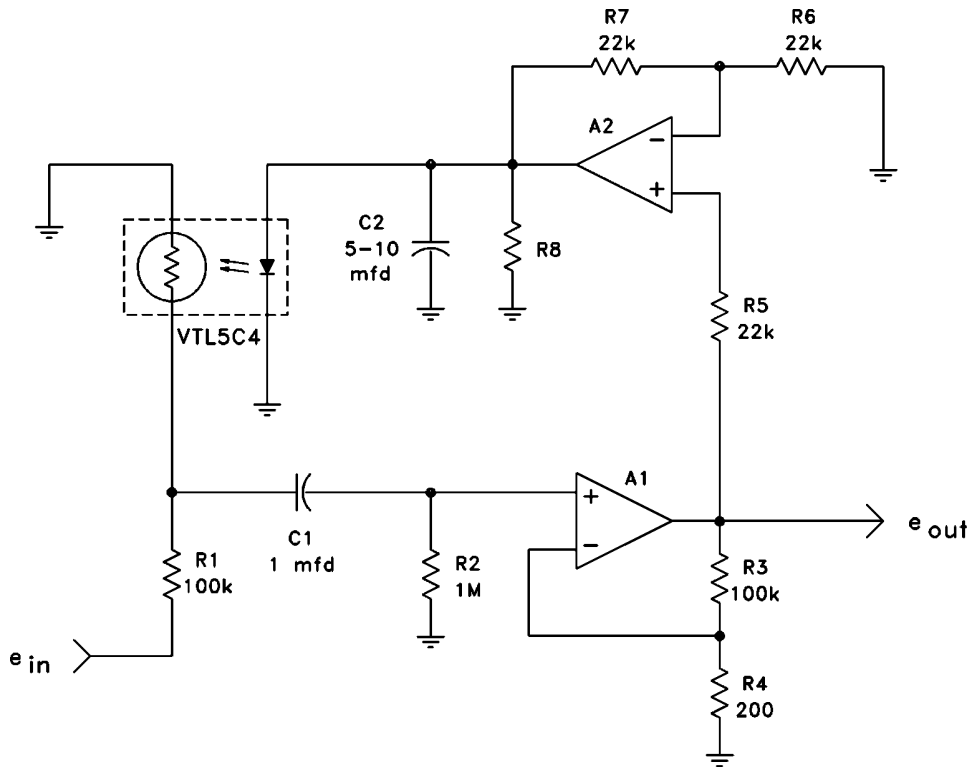

Figure 5. Peak Sensing Compressor with Constant Bandwidth

Variable bandwidth can be avoided if the AOI is used in a voltage divider circuit at the input of a fixed gain amplifier. For the same range of input signals, the amplifier gain must be 500 and the voltage divider must have a range of 1000:1. This configuration is shown in Figure 5. The AOI has been changed to a lower resistance unit to be able to work over the wider range. Also, A₁ is now a high input impedance, non-inverting stage to avoid a high insertion loss. This circuit is useful when the input voltage is high, which allows the use of a lower gain amplifier.

Speaker Power Limiting

Speakers that are driven from high power amplifiers must be protected from excess drive. While ordinary program levels may be well within the rating of the speaker, peaks do occur that can be destructive. The simplest solution is to use a compressor or limiter. Unfortunately, the maximum power that may be applied is not constant over the frequency range. Therefore, the limit must be set to provide protection at the lowest frequency that is expected.

To understand the requirements for effective speaker protection, a brief review of speaker power limitations follows. Figure 7 is a typical maximum sine wave voltage limit for a low frequency speaker commonly called a “woofer”. Above 200 Hz, the maximum allowed voltage or power is constant. The operating temperature at which wire insulation and coil bonding fail establishes this value. Below 200 Hz,

the voltage limit is determined by the allowable diaphragm excursion. For constant voltage on the speaker, the displacement doubles when the frequency is reduced by half. The maximum displacement is determined by the mechanical design of the speaker and exceeding the limit will produce extreme distortion and may even cause mechanical damage.

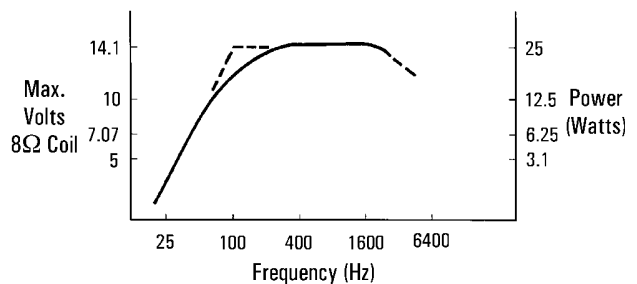

Figure 7. Maximum sine wave Voltage and Power for a Typical Woofer

Application Notes—Analog Optical Isolators

This reduced low frequency power rating can be accommodated by using a limited circuit which reduces the limit threshold when the frequency is below 200 Hz. Figure 8a shows a very simple circuit to do this. At low frequency, the gain of amplifier A_1 is unity. The amplifier has a 6 db/octave gain roll-off starting at 25 Hz and levels off at 100 Hz. Therefore it will take a signal that is four times as large at 100 Hz as at 25 Hz before limiting action starts. Breakpoints in the Frequency vs. Gain curve shown in Figure 8b can be set to match the speaker frequency dependent power limit. Also, potentiometer R_4 can be set to match the power rating and impedance of the speaker.

The threshold is set by the sum of V_{BE} of Q_1 and the forward voltage drops of D_1 and the LED, approximately 2.8V peak or 2.0 VRMS. Once

the threshold has been exceeded, current is injected into the LED of the AOI which attenuates the signal voltage. This voltage divider can be placed anywhere in the signal path. Once the limiter comes into play, the system frequency response will no longer be flat, but no distortion is introduced.

Automatic Gain Control

Automatic gain control (AGC) circuits have electrically programmable references or set points, but in other respects are the same as limiters or compressor circuits. Each has a forward gain amplifier and a loop which controls the gain of that amplifier.

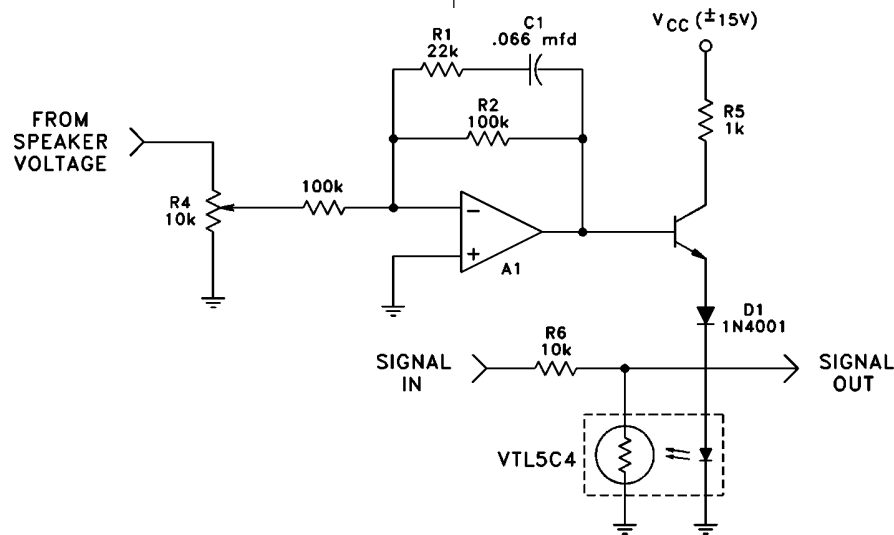

Figure 8a. Speaker Power Limiter with Frequency Compensation

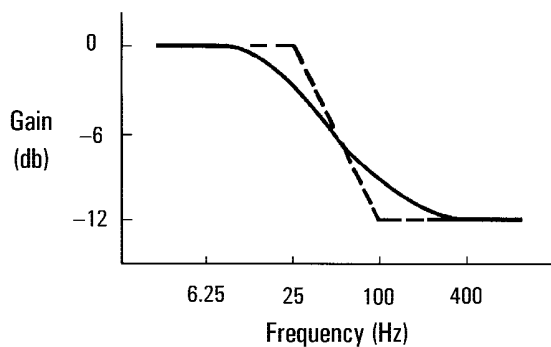

Figure 8b. Amplitude vs. Frequency for the Amplifier

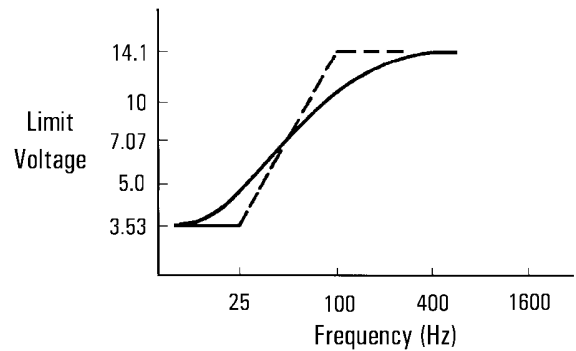

Figure 8c. System Voltage Limits

Application Notes—Analog Optical Isolators

Figure 9 shows an AGC circuit which consists of three main elements: a variable gain amplifier, full-wave active rectifier and a summing amplifier. The variable gain amplifier consists of op-amp A1 with potentiometric gain that is controlled by the resistance of the photocell of the AOI. The gain of this amplifier is:

$$\text{Gain} = 1 + R_2 / R_{\text{PHOTOCELL}}$$

With $R_2 = 100\text{k}$ ohms, the minimum gain is one since the cell "off" resistance is several megohms. The maximum gain is only 100 since the resistance of a typical VTL5C2 is 1000 ohms at an input current of 5.0 mA. If a range of 40 db (100:1) is not adequate, there are several options. R_2 can be increased, the LED drive current for the AOI can be increased or a lower resistance AOI such as the VTL5C4 can be used.

Amplifier A_2 together with diodes D_1 and D_2 and resistors R_3 , R_4 , and R_5 form a full-wave rectifier. The amplifier has a gain of one so the output is equal to the rectified input. There is no offset due to rectifier forward drops so this circuit will rectify signals all the way down to zero volts. Since the DC output of A_2 is not referenced to ground, op-amp A_3 and resistors R_6 , R_7 , R_8 , and R_9 form a fully differential amplifier which shifts the DC reference to ground.

Op-amp A_4 is used as an integrator. The signal from the full-wave rectifier is summed with a reference voltage V_{REF} and integrated. The time constant of the integrator is selected to limit the bandwidth of the control loop as well as assure stability of the loop. If the bandwidth is

too wide, the control loop will follow the signal on an instantaneous basis. The AOI alone is not very fast, but signals with frequencies of 30 – 60 Hz could be distorted if there were no time delay in the integrator.

The AGC circuit operates as follows. When there is no signal, the negative V_{REF} causes A_4 to be at a maximum positive output. Maximum forward current is injected into the LED, driving the cell to a low resistance and the gain of A_1 to the maximum where it stays until there is a signal. A signal at the input terminal is amplified, rectified and algebraically summed with V_{REF} at the inverting terminal of the integrator. The control loop will then act to make the absolute value of the rectified signal equal to the reference voltage. V_{REF} may be a fixed value or a function of some other parameter.

Electrically Controlled Gain

The gain of an amplifier can be electrically programmed using the circuit of Figure 10. An AOI with a center tapped photocell is used, one side in the signal amplifier channel and the other in the control loop. The signal amplifier consists of op-amp A_1 , resistors R_3 and R_2 which set the gain and the input resistor R_5 . The gain of this amplifier is given by:

$$G = \frac{e_{\text{out}}}{e_{\text{in}}} = \frac{(R_2 + R_3)}{R_2}$$

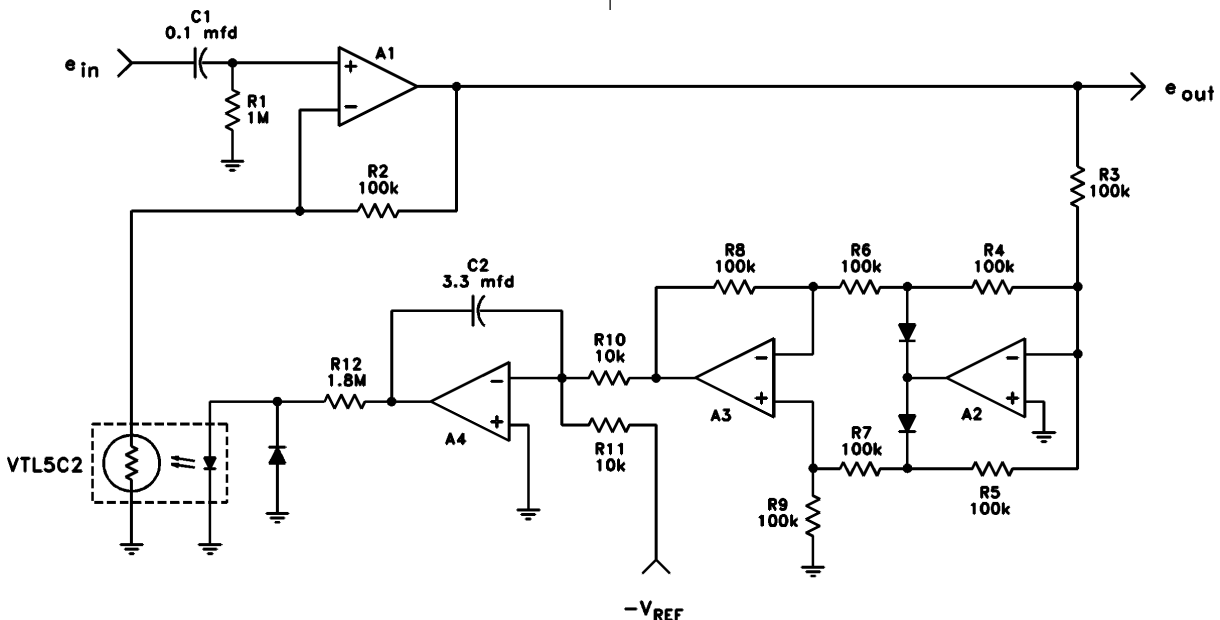

Figure 9. AGC Circuit with Electrical Setpoint

Application Notes—Analog Optical Isolators

The control loop consists of op-amp A_2 and resistors R_1 and R_4 . This circuit sets the LED current so that:

$$\frac{V_{REF}}{V_C} = \frac{(R_1 + R_4)}{R_1}$$

If we set:
and:
then:
or:
where

$$\begin{aligned} R_3 &= R_4 \\ R_1 &= R_2 \\ e_{out} / e_{in} &= V_{REF} / V_C \\ e_{out} &= e_{in} (V_{REF} / V_C) \\ V_C &= \text{control voltage} \end{aligned}$$

Note that R_1 and R_2 are the two halves of the cell. These two resistors match within 10% and track over a wide range within 5% so that the gain is closely set by V_C when V_{REF} is fixed.

The limits of operation are:

$$0 < V_C < V_{REF}$$

and the signal must never be so large that amplifier A_1 saturates when the gain is at maximum.

This circuit performs a dividing operation with e_{in} and V_C as the numerator and denominator respectively. The accuracy is limited by the tracking ability of the two sides of the photocell. The error due to matching can be eliminated by trimming R_4 .

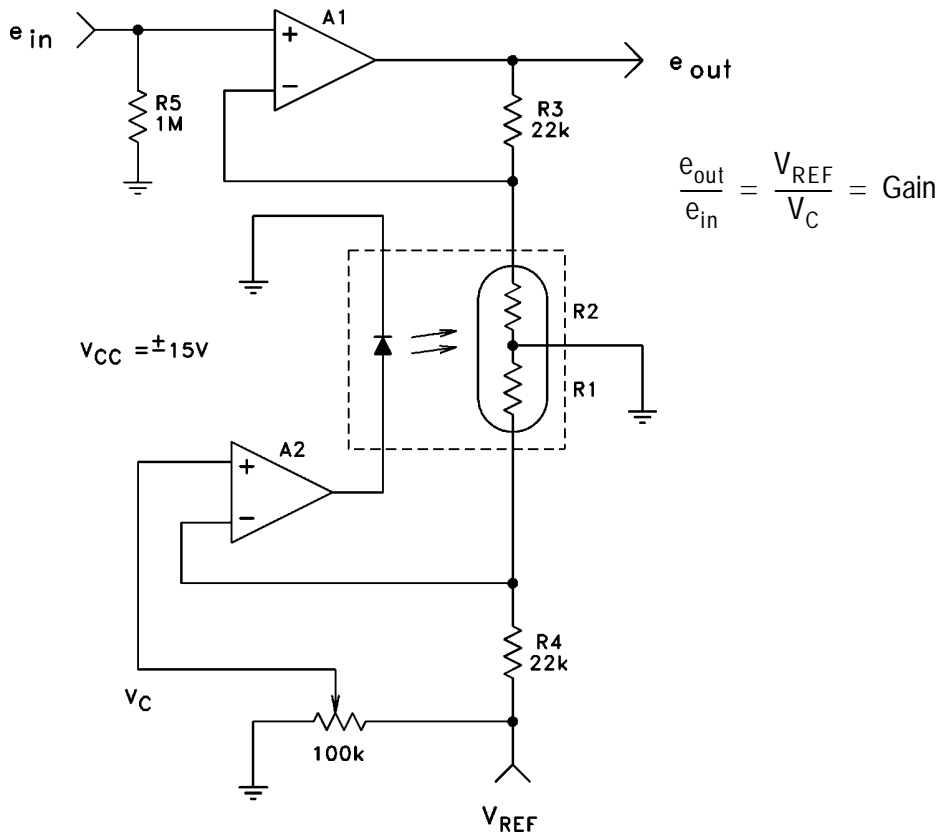

Figure 10. Electrically Programmable Gain

Application Notes—Analog Optical Isolators

APPLICATION NOTE #2

Handling and Soldering AOIs

All opto components must be handled and soldered with care, especially those that use a cast or molded plastic and lead frame construction like the LEDs used in AOIs.

In LED lead frame construction, the emitter chip is mounted directly to one lead and a wire bond is made from the chip to the other lead. The encapsulating plastic is the only support for the lead frame. Care must be taken when forming the leads of plastic opto packages. Excessive mechanical force can cause the leads to move inside the plastic package and damage the wire bonds. Weakened bonds can then "open up" under further mechanical or thermal stressing, producing open circuits.

In order to form leads safely, it is necessary to firmly clamp the leads near the base of the package in order not to transfer any force (particularly tension forces) to the plastic body. This can be accomplished either through use of properly designed tooling or by firmly gripping the leads below the base of the package with a pair of needle nose pliers while the leads are being bent.

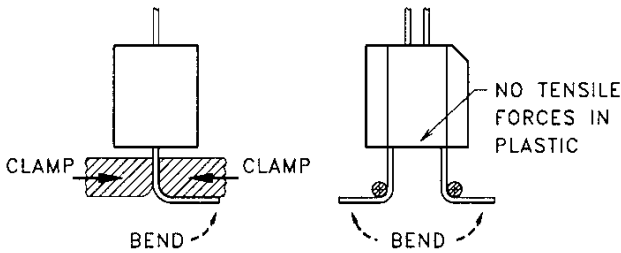

Examples of Tooling Fixtures Used to Form Leads

For highest reliability, avoid flush mounting the AOI body on the printed circuit board. This minimizes mechanical stress set up between the circuit board and the LED and photocell packages. It also reduces solder head damage to the packages.

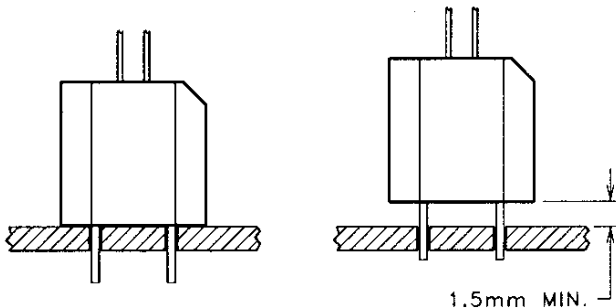

NOT RECOMMENDED RECOMMENDED

Good printed circuit board layout avoids putting any spreading (plastic under tension) force on the leads of the LED and photocell.

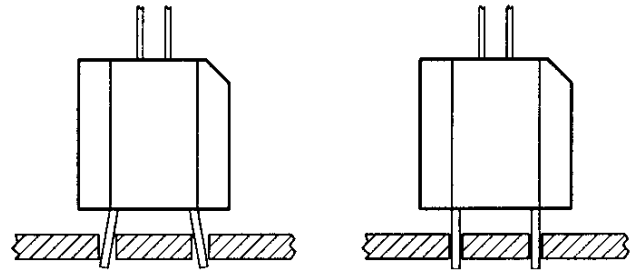

NOT RECOMMENDED RECOMMENDED

When hand soldering, it is important to limit the maximum temperature of the iron by controlling the power. It is best if a 15W or 25W iron is used. The maximum recommended lead soldering temperature (1/16" from the case for 5 seconds) is 260°C. An RMA rosin core solder is recommended.

Sn60 (60% tin / 40% lead) solder is recommended for wave soldering opto components into printed circuit boards. Other alternatives are Sn62 and Sn63. The maximum recommended soldering temperature is 260°C with a maximum duration of 5 seconds.

The amount of tarnish on the leads determines the type of flux to use when soldering devices with silver plated leads.

Condition of Leads	Recommended Flux
Clear Bright Finish (Tarnish Free)	RMA - Mildly Activated
Dull Finish (Minimal Tarnish)	RMA - Mildly Activated
Light Yellow Tint (Mild Tarnish)	RA - Activated
Light Yellow / Tan Color (Moderate Tarnish)	AC - Water Soluble, Organic Acid Flux
Dark Tan / Black Color (Heavy Tarnish)	Leads Need to be Cleaned Prior to Soldering

Cleaners designed for the removal of tarnish from the leads of electronic components are acidic and it is best to keep the immersion time as short as possible (less than 2 seconds) and to immediately wash all devices thoroughly in ten rinses of deionized water.

Application Notes—Analog Optical Isolators

The best policy is one which prevents tarnish from forming. Tarnish, which is a compound formed when silver reacts with sulfur (Ag_2S), can be prevented by keeping the components away from sulfur or sulfur compounds. Since two major sources of sulfur are room air and paper products, it is best to store the devices in protective packaging such as a "silver saver" paper or tightly sealed polyethylene bags.

After soldering, it is necessary to clean the components to remove any rosin and ionic residues. For a listing of recommended cleaning agents please refer to Application Notes #3.

APPLICATION NOTE #3 Recommended Cleaning Agents

The construction of an AOI consists of a cast epoxy LED, ceramic photocell, a molded case and epoxy as the end fill. This construction allows a wide variety of cleaning agents to be used after soldering.

In many cases the devices will be exposed to a post solder cleaning operation which uses one or more solvents to remove the residual solder flux and ionic contaminants. Only certain cleaning solvents are compatible with the plastics used in the AOI packages.

Recommended	Not Recommended
Arklone A	Acetone
Arklone K	Carbon Tetrachloride
Arklone F	Methyl Ethyl Ketone
Blaco-Tron DE-15	Methylene Chloride
Blaco-Tron DI-15	Trichloroethylene (TCE)
Freon TE	Xylene
Freon TES	Trichloroethane FC-111
Freon TE-35	Trichloroethane FC-112
Freon TP	Freon TF
Freon TF-35	Freon TA
Genesolv D	Freon TMC
Genesolv DE-15	Freon TMS
Genesolv DI-15	Genesolv DA
Isopropyl Alcohol	Genesolv DM
Water	Genesolv DMS

This listing of recommended/not recommended solvents represents only a very small percentage of available chemical cleaning agents. Even with this list of recommended solvents it is important to be aware that:

1. Solvent exposure times should be as short as possible.

2. The exact requirement of the cleaning process will vary from customer to customer and application to application.
3. Additives and concentrations will vary from supplier to supplier.

Because of these uncertainties, our recommendation is that all customers carefully evaluate their own cleaning process and draw their own conclusions about the effectiveness and reliability of the process. PerkinElmer cannot assume any responsibility for damage caused by the use of any of the solvents above or any other solvents used in a cleaning process.